

STABILIZATION SPECIFICATIONS

- PERMANENT STABILIZATION IS DEFINED AS A MINIMUM UNIFORM 70% PERMANENT VEGETATIVE COVER OR OTHER PERMANENT NON-VEGETATIVE COVER WITH A DENSITY SUFFICIENT TO RESIST ACCCELERATED EROSION. AFTER APPROPRIATE ADVISORY CARE, THE DISTURBED AREAS SHALL BE RESTORED TO THE DISTURBED AREAS. DISTURBED AREAS WHICH ARE NOT AT FINISHED GRADE AND WHICH WILL BE RE-DISTURBED SPECIFICALLY, DISTURBED AREAS WHICH ARE AT FINISHED GRADE OR WHICH WILL NOT BE RE-DISTURBED SPECIFICALLY, AND DISTURBED AREAS WHICH ARE AT FINISHED GRADE AND WHICH WILL NOT BE RE-DISTURBED SPECIFICALLY, SHALL BE RESTORED TO ORIGINAL CONDITIONS IN ACCORDANCE WITH THE PERMANENT VEGETATIVE STABILIZATION SPECIFICATIONS.
- AN EROSION CONTROL BLANKET WILL BE INSTALLED ON ALL DISTURBED SLOPES STEEPER THAN 3:1, COMMONWEALTH, AND DISTURBED AREAS WITHIN 50' OF WATERS OF THE COMMONWEALTH.
- WHEN A FINISHED GRADE IS TO BE APPLIED TO A DISTURBED AREA, THE METHOD OF FINISHING SHALL BE LIMITED TO SOFTENING TO STEEPER THAN 3:1. THE MACHINERY SHOULD BE LIMITED TO TRACK-BLADDER AND TRACK-BLADDER MACHINERY. A WOOD CHIPPED FILTER MAY BE SPREAD OVER THE STRAW MAT AT A RATE OF 200 LB/Acre. FINISHING TRACK-BLADDER MACHINERY UP AND DOWN THE SLOPE, LEAVING THE TRACK MARKS PARALLEL TO THE CONTOUR. IF A BUILDUP IS USED, THE RATE SHALL BE IN THE OVER-COMPACTION.
- ROCK SHALL BE PLACED AT A MINIMUM DEPTH OF 6 INCHES ON ALL DISTURBED AREAS TO BE RE-DISTURBED.

PERMANENT SEEDING

- ALL DISTURBED AREAS THAT ARE NOT TO BE PAVED SHALL BE COVERED WITH PERMANENT TURF OR A MULCHED PLANNING BED (SHREDED HARDWOOD TREE BARK WHICH TO MAINTAIN PERMANENT). UNLESS OTHERWISE DIRECTED BY THE OWNER, PERMANENT SEEDING AND RIFP IN THE PERMANENT OF ACCCELERATED RUN-OFF - CLEAN WAY OR STRAW MULCHING SHALL BE REQUIRED ON DEEP EROSION-DISTURBED AREAS. STRAW MULCHING SHALL BE APPLIED TO ALL DISTURBED AREAS ON STRAW MULCHING AT A RATE OF 150 GALLONS/Acre. CLEAN WAY OR STRAW MULCHING SHALL NOT BE APPLIED TO SLOPES STEEPER THAN 3:1.
- PERMANENT TURF LAWN SEED: APPLICATION RATE: SEEDING DATES: MAY 1 to JUN 1 or AUG 1 to OCT 1
WINTER RYE: 100 LBS/Acre
4: LBS/Acre
MAY 1 to JUN 1 or AUG 1 to OCT 1
- PERMANENT TURF LAWN SEED: APPLICATION RATE: SEEDING DATES: MAY 1 to JUN 1 or AUG 1 to OCT 1
WINTER RYE: 100 LBS/Acre
4: LBS/Acre
MAY 1 to JUN 1 or AUG 1 to OCT 1
- PERMANENT TURF LAWN SEED: APPLICATION RATE: SEEDING DATES: MAY 1 to JUN 1 or AUG 1 to OCT 1
WINTER RYE: 100 LBS/Acre
4: LBS/Acre
MAY 1 to JUN 1 or AUG 1 to OCT 1

PERMANENT TURF LAWN SEED	APPLICATION RATE	SEEDING DATES
WINTER RYE	100 LBS/Acre	MAY 1 to JUN 1 or AUG 1 to OCT 1
4: LBS/Acre		MAY 1 to JUN 1 or AUG 1 to OCT 1

TEMPORARY SEEDING

- IN ORDER TO ESTABLISH A QUICK VEGETATIVE COVER OVER DISTURBED AREAS, THE FOLLOWING TEMPORARY SEEDING MIXTURE SHALL BE USED DURING THE PERIOD FROM OCTOBER 15 TO MARCH 15. THIS SEEDING MIXTURE SHALL BE APPLIED AT A RATE OF 3 TONS PER Acre. THE MIXTURE SHALL BE APPLIED TO ALL DISTURBED AREAS WHICH WILL NOT BE RE-DISTURBED SPECIFICALLY, AND DISTURBED AREAS WHICH ARE AT FINISHED GRADE OR WHICH WILL NOT BE RE-DISTURBED SPECIFICALLY, SHALL BE RESTORED TO ORIGINAL CONDITIONS IN ACCORDANCE WITH THE PERMANENT VEGETATIVE STABILIZATION SPECIFICATIONS.
- TEMPORARY SEEDING: APPLICATION RATE: SEEDING DATES: MAY 1 to JUN 1 or AUG 1 to OCT 1
ANNUAL RYEGRASS: 100 LBS/Acre
4: LBS/Acre
MAY 1 to JUN 1 or AUG 1 to OCT 1
- TEMPORARY SEEDING: APPLICATION RATE: SEEDING DATES: MAY 1 to JUN 1 or AUG 1 to OCT 1
ANNUAL RYEGRASS: 100 LBS/Acre
4: LBS/Acre
MAY 1 to JUN 1 or AUG 1 to OCT 1
- TEMPORARY SEEDING: APPLICATION RATE: SEEDING DATES: MAY 1 to JUN 1 or AUG 1 to OCT 1
ANNUAL RYEGRASS: 100 LBS/Acre
4: LBS/Acre
MAY 1 to JUN 1 or AUG 1 to OCT 1

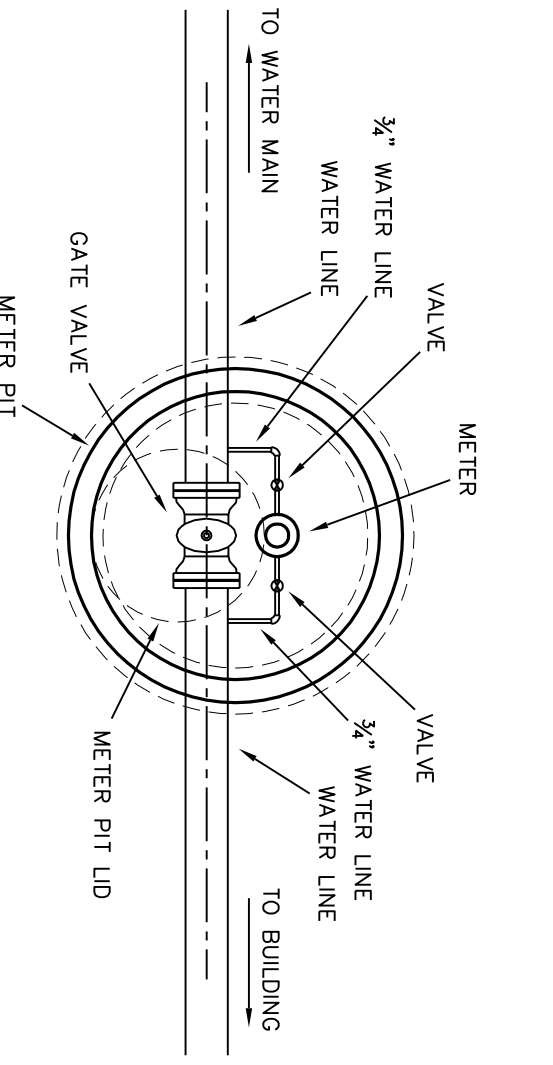

- LINE'S OVER 75' IN LENGTH FROM MAIN TO BUILDING MUST USE A PIT AND METER INSTALLED AS CLOSE TO MAIN AS FIELD CONDITIONS WILL ALLOW.

LEAK DETECTION METER

DESIGN BY: BIF
CHECK BY: E3
DATE: MARCH 2003
DWG NO. CHB-16-14

- NOTE:** ALL WATER SERVICES AND SEWER LATERALS SHALL BE EXTENDED A MINIMUM OF 5' FROM THE ELECTRIC, TELEPHONE, CABLE OR ANY OTHER UTILITY APPROPRIATE.

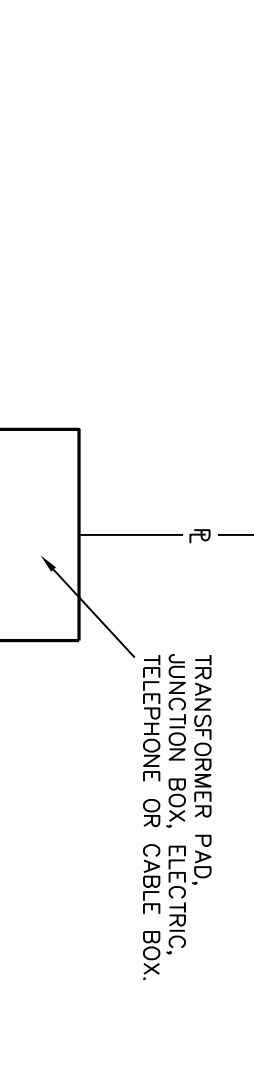

UTILITY SERVICE HORIZONTAL SEPARATION DETAIL

- NOTE:** ALL WATER SERVICES AND SEWER LATERALS SHALL BE EXTENDED A MINIMUM OF 5' FROM THE ELECTRIC, TELEPHONE, CABLE OR ANY OTHER UTILITY APPROPRIATE.

UTILITY SERVICE PLACEMENT

DESIGN BY: BIF
CHECK BY: E3
DATE: MARCH 2003
DWG NO. CHB-16-15

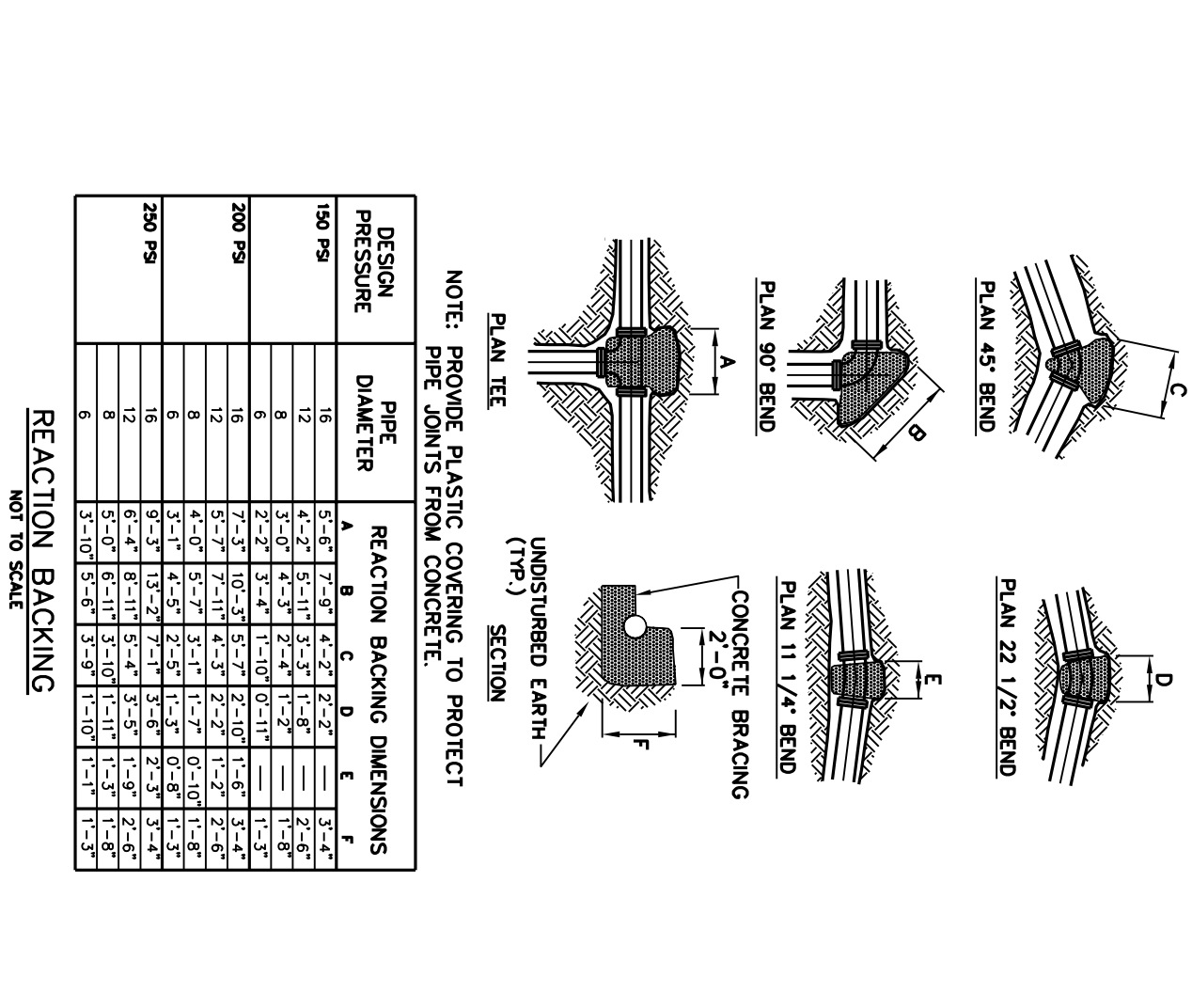

HORIZONTAL REACTION BACKING

DESIGN BY: BIF
CHECK BY: E3
DATE: MARCH 2003
DWG NO. CHB-16-03

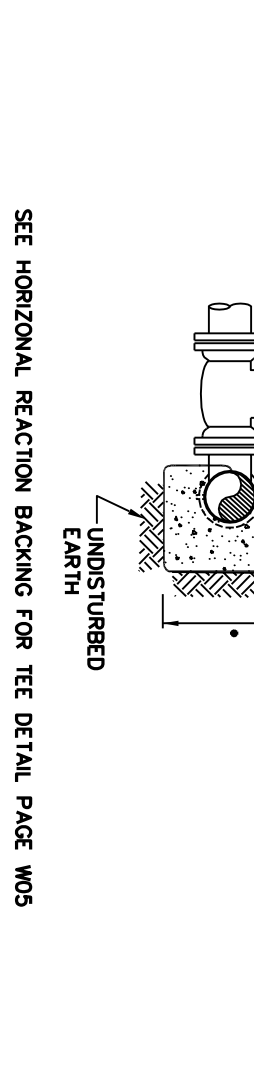
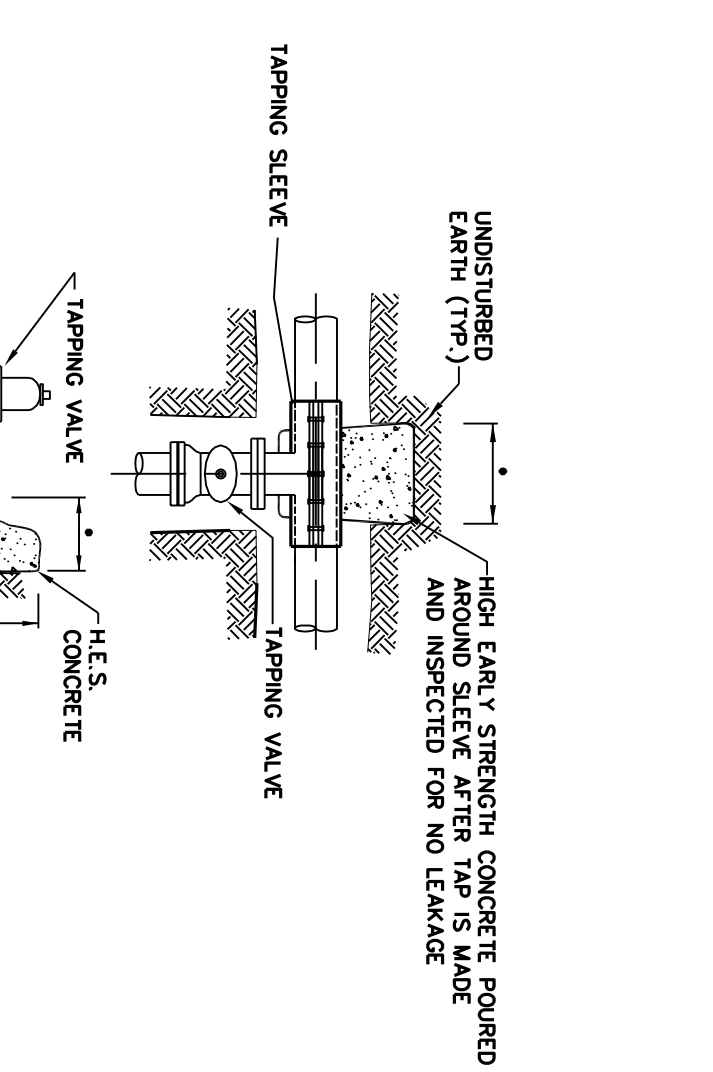

TAPPING SLEEVE & VALVE

DESIGN BY: BIF
CHECK BY: E3
DATE: MARCH 2003
DWG NO. CHB-16-04

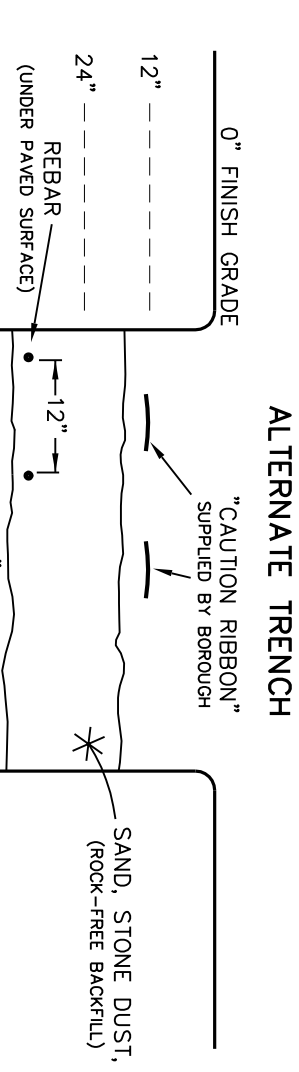
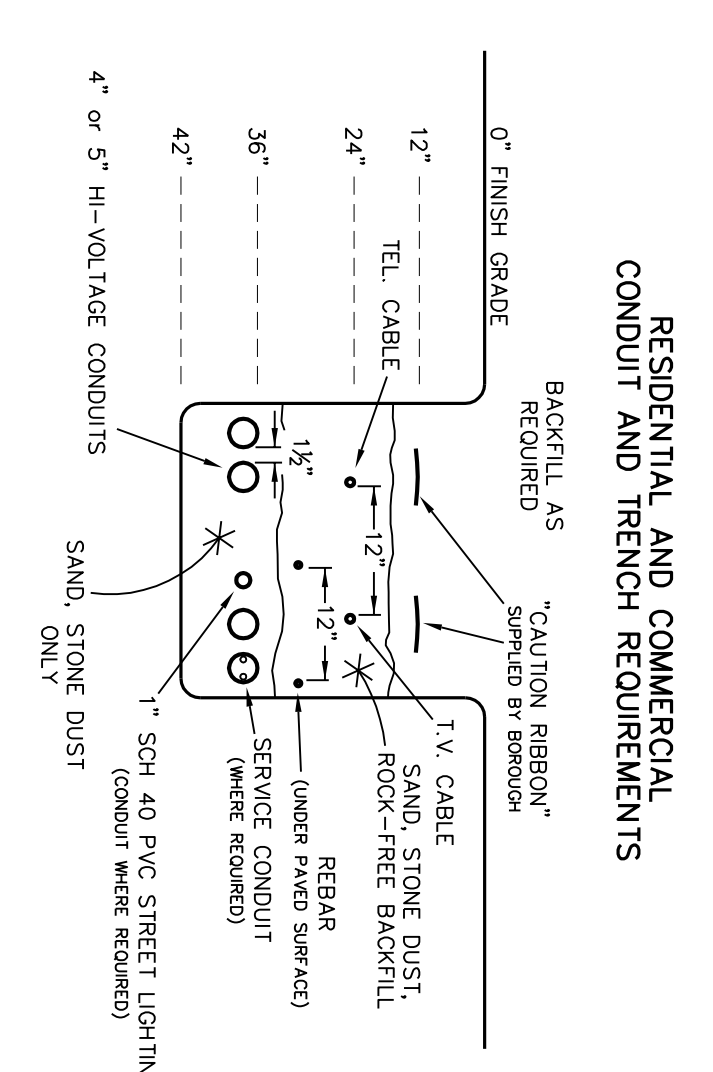

CONDUIT & TRENCH DETAIL

DESIGN BY: BIF
CHECK BY: E3
DATE: MARCH 2003
DWG NO. CHB-16-11

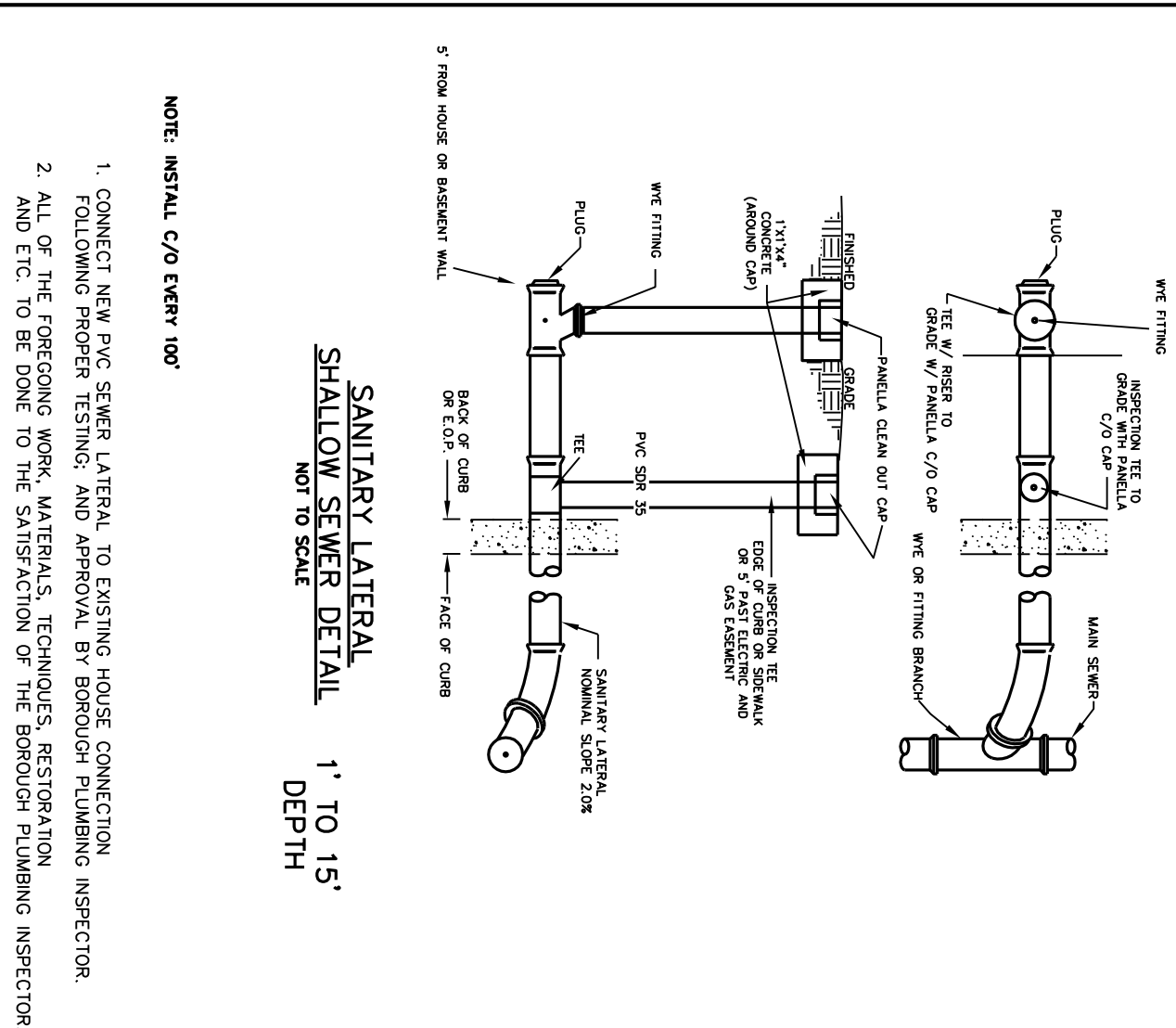

SANITARY LATERAL - SHALLOW SEWER

DESIGN BY: BIF
CHECK BY: E3
DATE: MARCH 2003
DWG NO. CHB-310

- GENERAL INSTRUCTIONS FOR INSTALLING UNDERGROUND ELECTRIC FACILITIES IN DEVELOPMENTS**
- PROTECT TRENCHES FROM CAVE-INS.
 - BE SURE BOTTOM OF TRENCH IS FREE OF IRREGULARITIES FOLLOWING AND VALLES, ROCKS, ETC.
 - CEMENT ALL CONDUIT JOINTS AT THE END OF EACH WORK DAY TO PREVENT DRY AND CRACKS FROM FORMING.
 - DO NOT OVER STRESS CEMENTED JOINTS BY BENDING BEFORE CEMENT HAS SET (BENDS AT JOINTS CAUSE WIRE PULLING DEVICES TO HANG-UP ON EDGES).

INSTALLING UNDERGROUND ELECTRIC

DESIGN BY: BIF
CHECK BY: E3
DATE: MARCH 2003
DWG NO. CHB-311

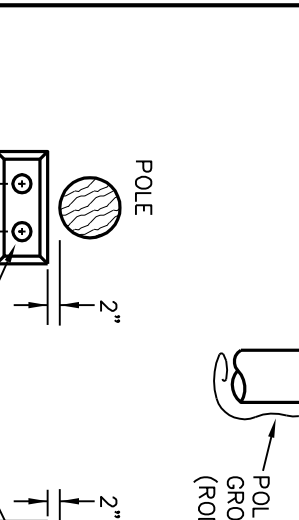
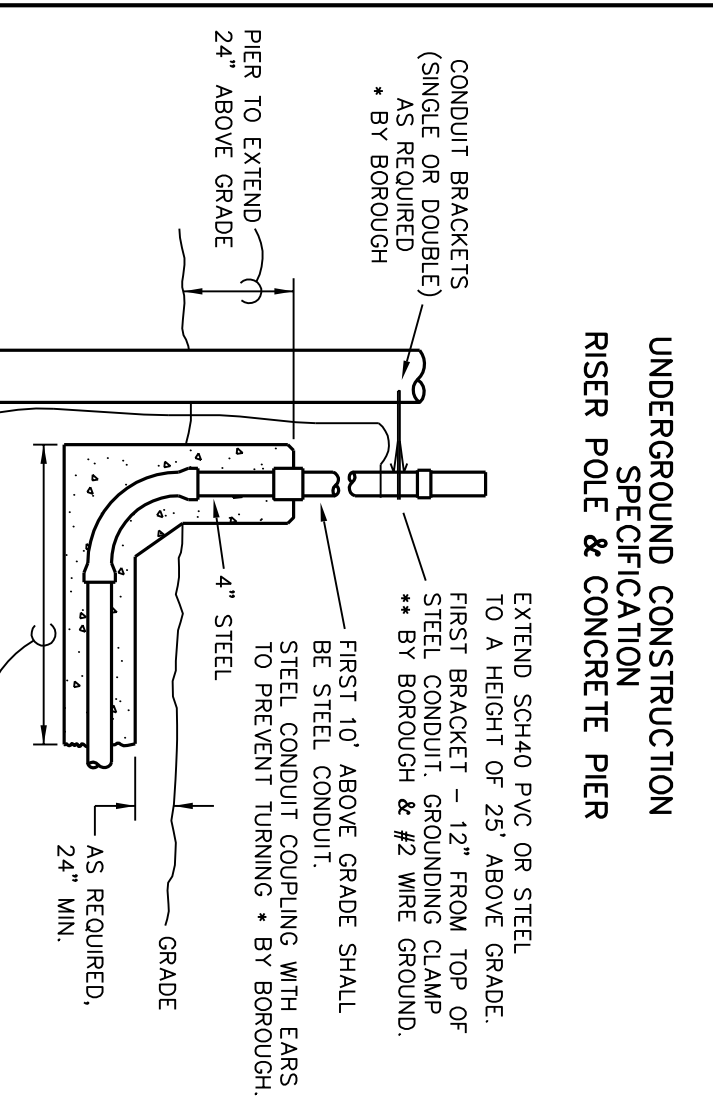

RISER POLE & CONCRETE PIER

DESIGN BY: BIF
CHECK BY: E3
DATE: MARCH 2003
DWG NO. CHB-311

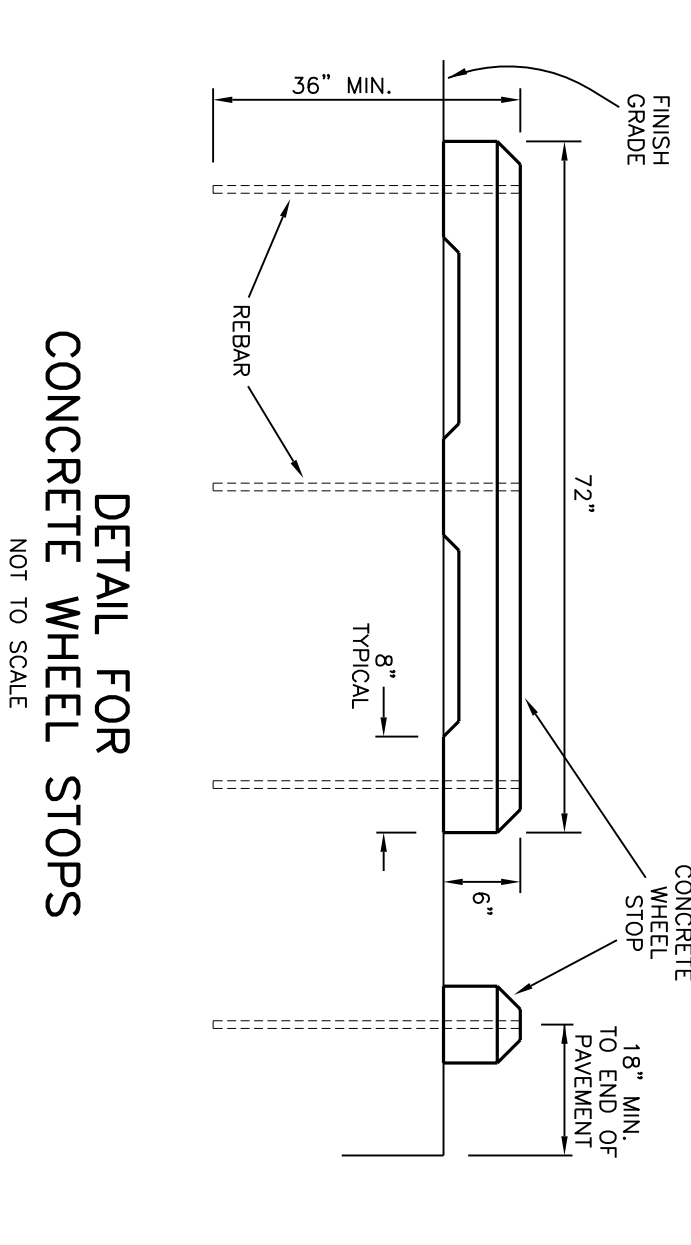

Restoration of Pavement Over Pipe

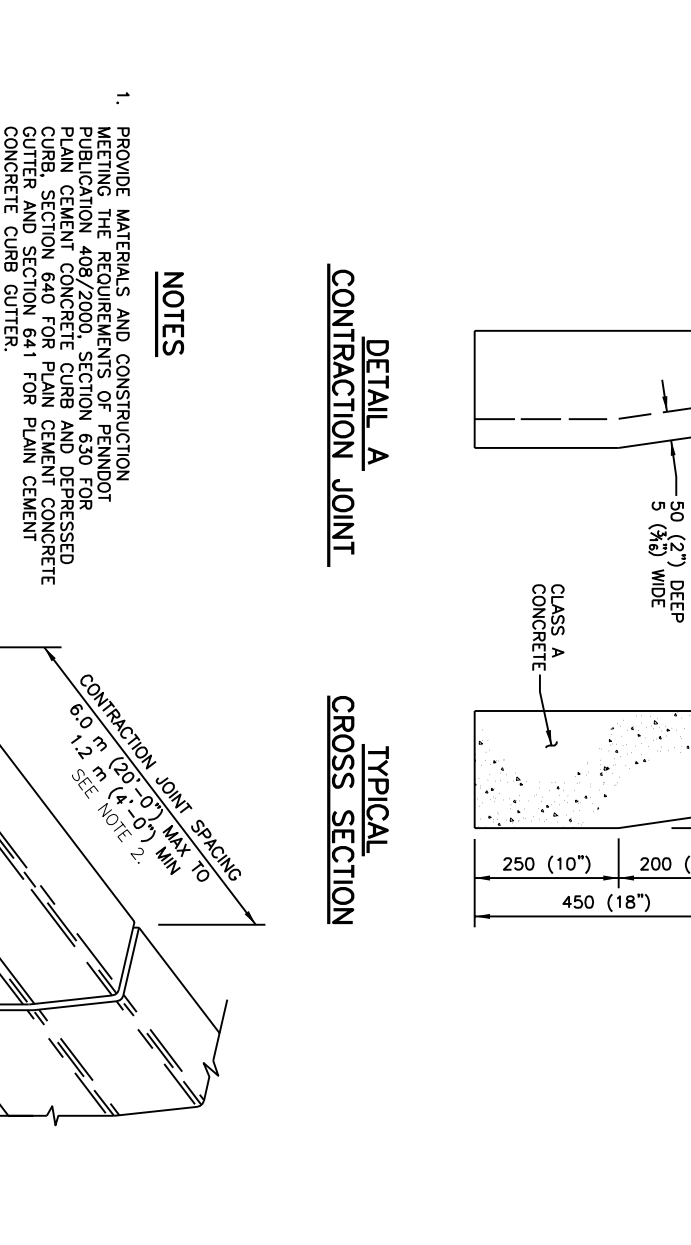
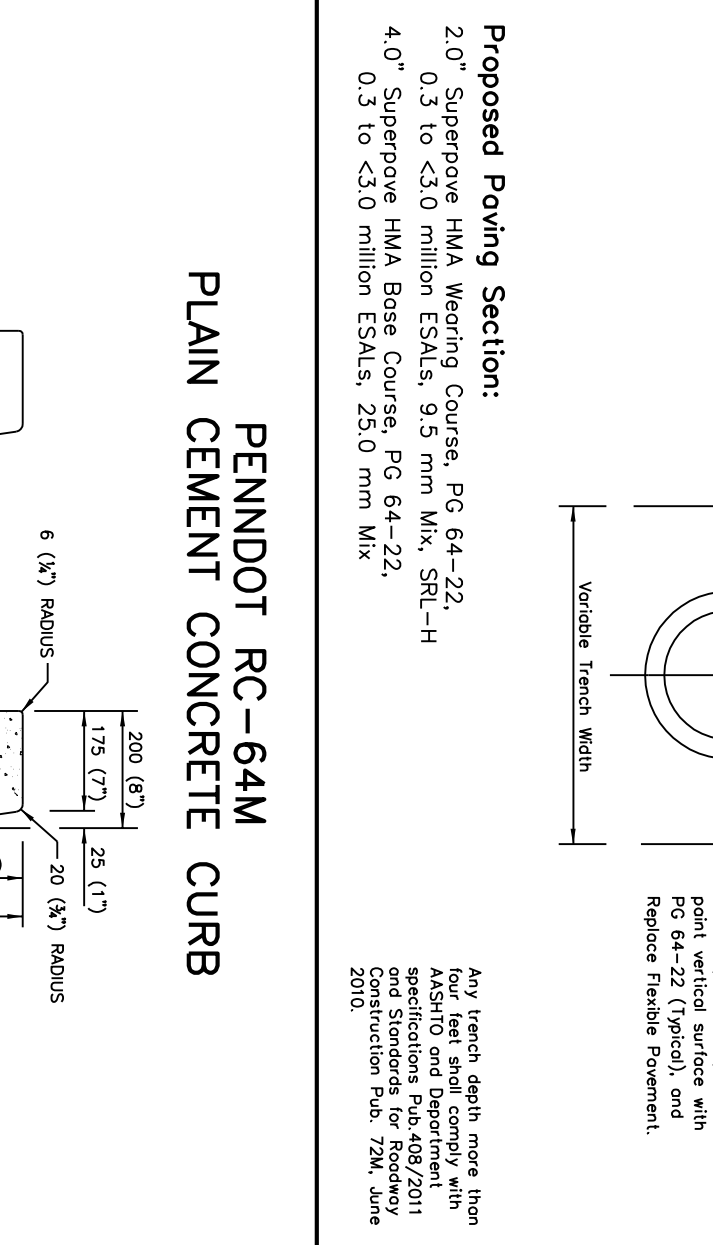
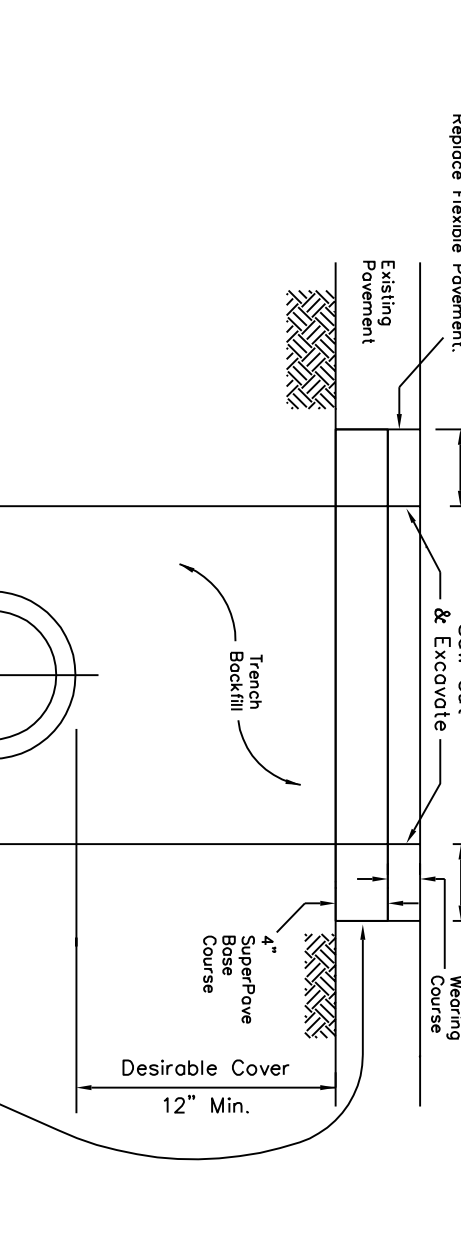

- NOTES:**
- PROVIDE MATERIALS AND CONSTRUCTION PERMANENT RECORD SECTION 220 FOR REVISION. ADVISE SECTION 220 FOR COLOR SECTION AND FOR PLAIN CEMENT CONCRETE CURB OUTER.
 - SPACE CONTRACTION JOINTS IN UNIFORM LENGTHS OR SECTIONS. CONTRACTION JOINTS SHALL BE PLACED AT SIGHTLINES AND AT 10' TO 15' INTERVALS. CONTRACTION JOINTS SHALL BE PLACED AT END OF CURB. CURB SURF TO BE TREATED AT END OF CURB SURF.
 - SEE RC-30W FOR PLAIN CEMENT CONCRETE CURB SURF TREATMENT AT END OF CURB SURF.
 - ALL DIMENSIONS ARE IN UNITS UNLESS OTHERWISE NOTED. U.S. CUSTOMARY UNITS IN [] PRECEDENCE.

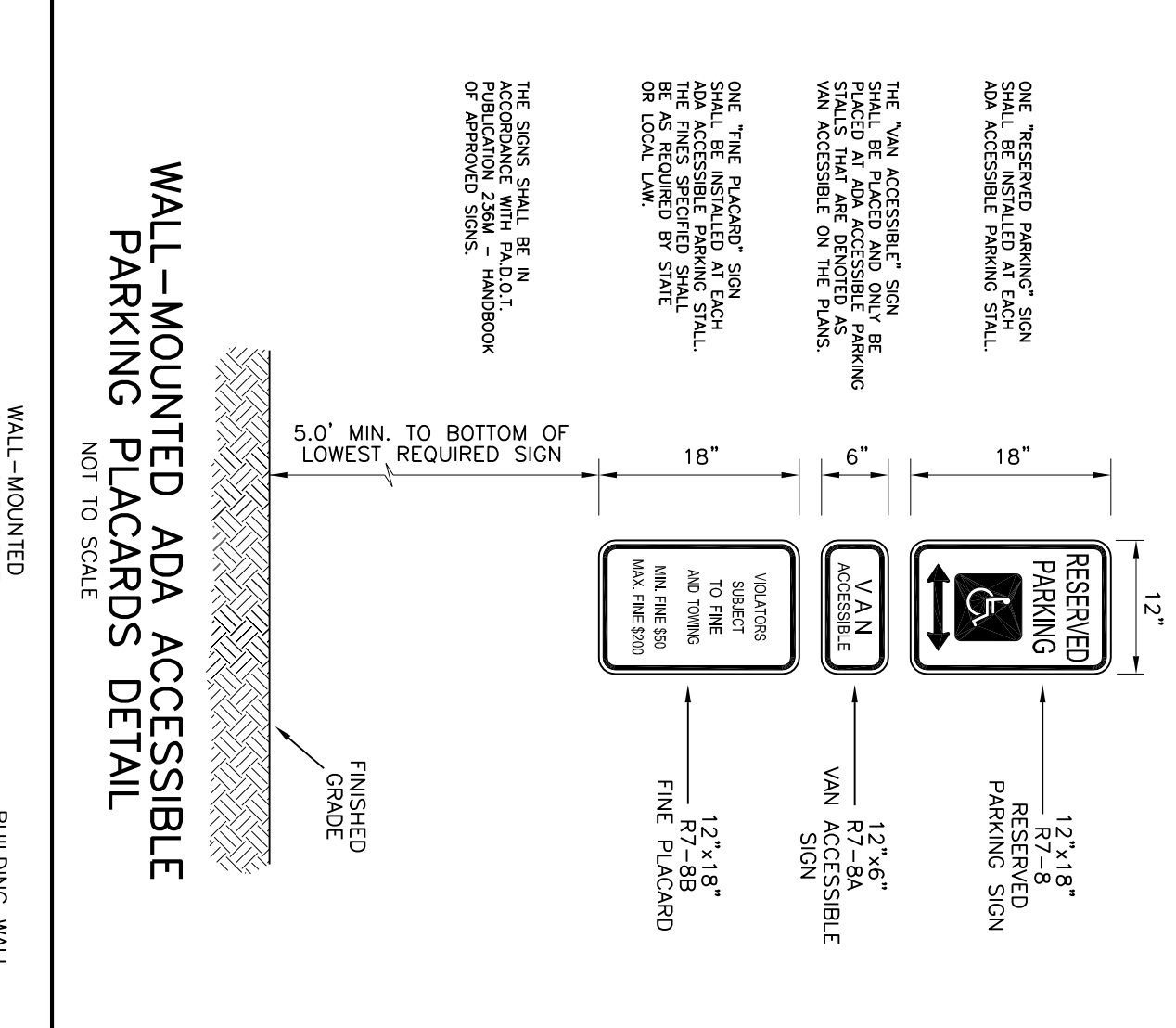

WALL-MOUNTED ADA ACCESSIBLE PARKING PLACARDS DETAIL

DESIGN BY: BIF
CHECK BY: E3
DATE: MARCH 2003
DWG NO. CHB-310

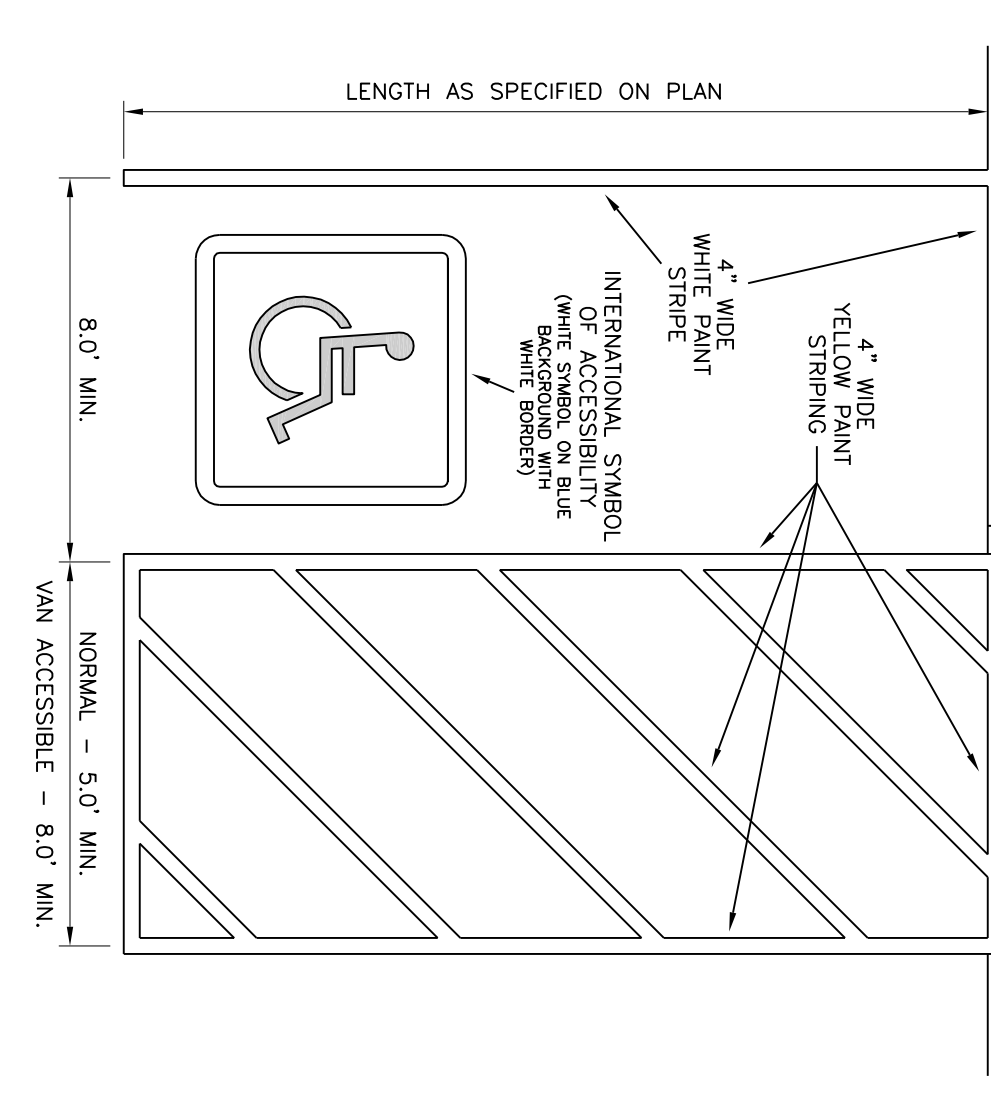

ADA ACCESSIBLE PARKING STALL DETAIL

- NOTES:**
- THE ORIGINAL DRAWING AND THE INFORMATION SHOWN THEREON ARE THE PROPERTY OF DENNIS E. BLACK ENGINEERING, INCORPORATED. ANY REVISIONS SHALL BE NOTED BY THE ARCHITECT OR ENGINEER.
 - ALL DIMENSIONS ARE IN UNITS UNLESS OTHERWISE NOTED. U.S. CUSTOMARY UNITS IN [] PRECEDENCE.

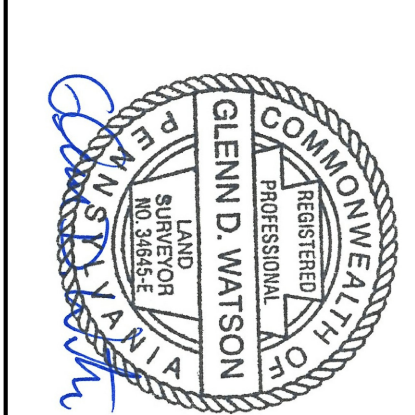

Site and Utility Plan
for
King Street Church of The United Brethren in Christ
located in
Borough of Chambersburg, Franklin County, PA

DENNIS E. BLACK ENGINEERING, INCORPORATED
ENGINEERING-SURVEYING-PLANNING
2400 PHILADELPHIA AVENUE ♦ 222 NORTH SECOND STREET
CHAMBERSBURG, PA 17201 ♦ MCCONNELL (717)485-4028
(717)263-8794 (888)238-0661

APP.	DATE	SCALE	BY	DATE	SCALE	BY	DATE	SCALE	BY
APP.	DATE	SCALE	BY	DATE	SCALE	BY	DATE	SCALE	BY

16-14
SHEET 2 OF 2